

XHZ Series Style Air Gripper



MHZ2-25D

Ordering Code

XHZ **2** — **16** **D** — **1**

Model
XHZ: Parallel fingers
XHZL: Long stroke
finger

**Finger
Quantity**
2PCS

Bore Size
6mm~40mm

Action Type
D: Double Action
S: Single Action
(Normally open)
C: Single-Action
(Normally closed)

Claw Form
Blank: Standard Basic Type
1: Side screw installation
2: Opening and closing direction
through-hole installation
N: Narrow basic type
N1: Side screw hole installation
N2: Opening and closing direction
through hole installation

Graphic Symbol



Double-acting internal grip



Double-acting External grip



Single acting normally
closed Internal grip



Single acting normally
closed External grip

Specification

Bore(mm)		6	10	16	20	25	32	40
Working Medium		Air (to be filtered by 40 μm filter element)						
Operating pressure	Double-action	0.15~0.7	0.2~0.7		0.1~0.7		0.1~0.7	
	Single-action	0.3~0.7	0.35~0.7		0.25~0.7		0.25~0.7	
Ambient fluid temperature				-10~60°C				
Repeatability(mm)				±0.01			±0.02	
The highest frequency of use				180(XHZL Series 120)(c.p.m)			60(c.p.m)	
Lubrication				Not required				
Action type				Double acting-Single acting				
Auto switch(optional)				Solid state auto switch				
Port size		M3×0.5			M5×0.8			

Gripping force

Model	Gripping force N				Opening/Closing (Both sides)mm
	RMS each finger gripping force				
	Double-acting		Single acting		
	External	Internal	External	Internal	
XHZ-6□	3.3	6.1	1.9	3.7	4
XHZ-10□	11	17	7.1	13	4
XHZ-16□	34	45	27	38	6
XHZ-20□	42	66	33	57	10
XHZ-25□	65	104	45	83	14
XHZ-32□	158	193	131	161	22
XHZ-40□	254	318	217	267	30

Model	Gripping force N				Opening/ Closing (Both sides)mm
	RMS each finger gripping force				
	Double-acting		Single acting		
	External	Internal	External	Internal	
XHZL-10□	11	17	7.1	13	8
XHZL-16□	34	45	27	38	12
XHZL-20□	42	66	33	57	18
XHZL-25□	65	104	50	85	22

□ =Express D=Double-acting S=Single acting(normally closed) C=Single acting(normally open)

XHZ Series Style Air Gripper

Overall Dimensions

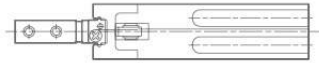

XHZ-6 □ (Φ6)
Double acting
Single acting

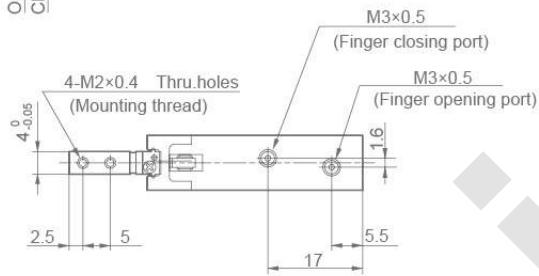
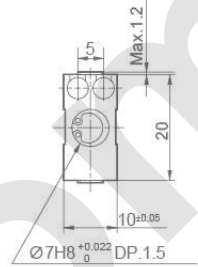
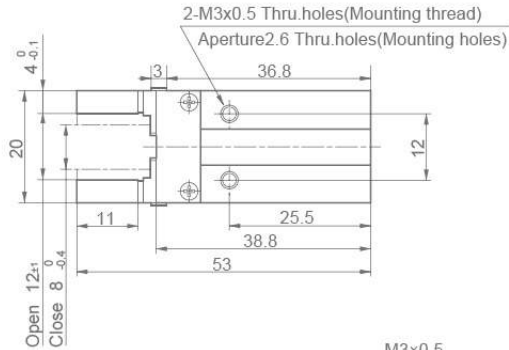

Auto switch mounting groove dimensions

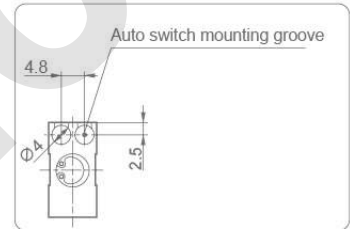

For single acting, the port on one side will turn into breathing hole.

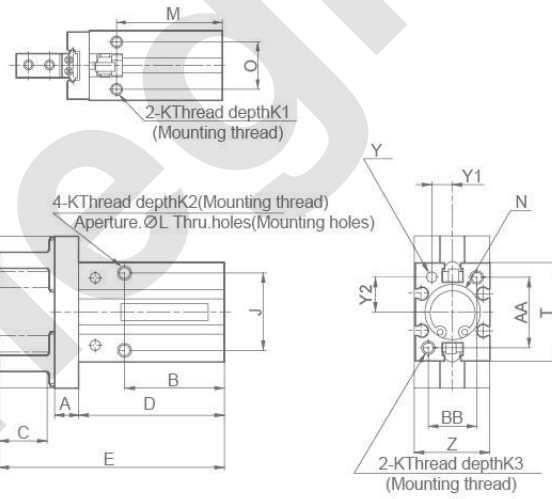

XHZ-10 □
Auto Switch Mounting Groove Dimensions

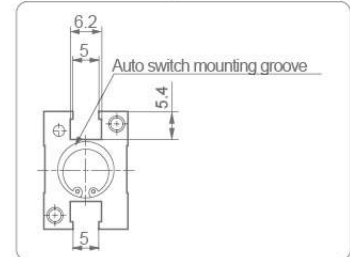

Note) Through-hole mounting is not possible when using the auto switch at the square groove.

XHZ-□□ (Φ10~Φ40)
Double acting
Single acting

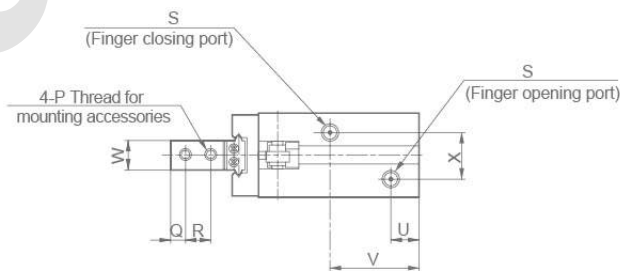

XHZ-□□
Auto Switch Mounting Groove Dimensions

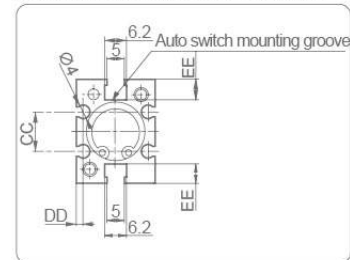

Note) Through-hole mounting is not possible when using the auto switch at the square groove.

For single acting, the port on one side will turn into breathing hole.

XHZ Series Style Air Gripper

Dimension Sheet

Bore(mm)	A	B	C	D	E	F	G	H	I	J	K	K1	K2	K3	ΦL	M	N	O	P	Q	
10	6	23	12	37.8	57	29	15.2 ^{+2.2} ₀	11.2 ⁰ _{-0.7}	4 ⁰ _{-0.1}	16	M3×0.5	6	5.5	6	2.6	27	Φ11H9 ^{+0.043} ₀	Dp:2	11.4	M2.5×0.45	3
16	7.5	24.5	15	42.5	67.3	38	20.9 ^{+2.2} _{0.2}	14.9 ⁰ _{-0.7}	5 ⁰ _{-0.1}	24	M4×0.7	4.5	8	8	3.4	30	Φ17H9 ^{+0.043} ₀	Dp:2	16	M3×0.5	4
20	9.5	29	20	52.8	84.8	50	26.3 ^{+2.2} _{0.2}	16.3 ⁰ _{-0.7}	8 ⁰ _{-0.1}	30	M5×0.8	8	10	10	4.3	35	Φ21H9 ^{+0.052} ₀	Dp:3	18.6	M4×0.7	5
25	11	30	25	63.6	102.7	63	33.3 ^{+2.5} _{0.2}	19.3 ⁰ _{-0.8}	10 ⁰ _{-0.1}	36	M6×1	10	12	12	5.1	36.5	Φ26H9 ^{+0.052} ₀	Dp:3.5	22	M5×0.8	6
32	12	40(49)	29	67(76)	113(122)	97	48 ^{+2.5} ₀	26 ⁰ _{-0.5}	12 ⁰ _{-0.1}	46	M6×1	10	13	13	5.1	48(57)	Φ34H9 ^{+0.052} ₀	Dp:4	26	M6×1	7
40	15	49(62)	36	83(96)	139(152)	119	60 ^{+2.7} ₀	30 ⁰ _{-0.5}	14 ⁰ _{-0.1}	56	M8×1.25	13	16	17	6.6	58(71)	Φ42H9 ^{+0.052} ₀	Dp:4	32	M8×1.25	9

Bore(mm)	R	S	T	U	V	W	X	Y	Z	Y1	Y2	AA	BB	CC	DD	EE	
10	5.7	M3×0.5	23	9	19	5 ⁰ _{-0.05}	11	Φ2H9 ^{+0.025} ₀	Dp:3	16.4±0.05	5.2±0.02	7.6±0.02	18	12	-	-	
16	7	M5×0.8	30.6	7.5	19	8 ⁰ _{-0.05}	13	Φ3H9 ^{+0.025} ₀	Dp:3	23.6±0.05	6.5±0.02	11±0.02	22	15	11.6	2.1	5.8
20	9	M5×0.8	42	10	23	10 ⁰ _{-0.05}	15	Φ4H9 ^{+0.03} ₀	Dp:4	27.6±0.05	7.5±0.02	16.8±0.02	32	18	14	2.1	9
25	12	M5×0.8	52	10.7	23.5	12 ⁰ _{-0.05}	20	Φ4H9 ^{+0.03} ₀	Dp:4	33.6±0.05	10±0.02	21.8±0.02	40	22	19	3.5	11.5
32	14	M5×0.8	60	11	31(37)	15 ⁰ _{-0.05}	24	Φ5H9 ^{+0.03} ₀	Dp:5	40±0.1	12±0.02	23±0.02	46	26	24	3.3	11.5
40	17	M5×0.8	72	12	38(45)	18 ⁰ _{-0.05}	28	Φ5H9 ^{+0.03} ₀	Dp:5	48±0.1	14±0.02	29±0.02	56	32	29.4	3.7	13

Overall Dimensions

XHZL-□□ (Φ10~Φ25)
Double acting
Single acting

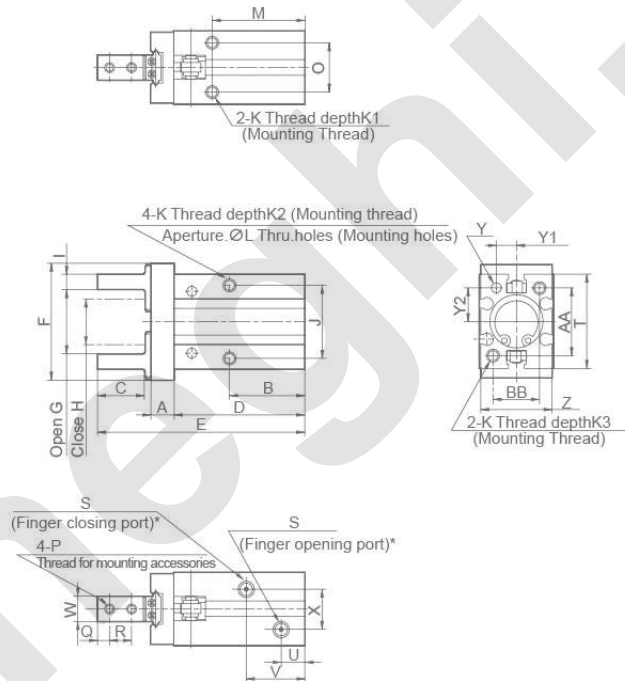

XHZL-10□
Auto Switch Mounting Groove Dimensions

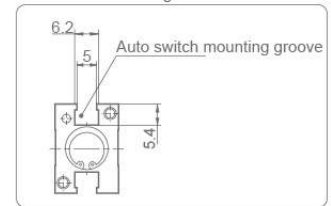

Note) Through-hole mounting is not possible when using the auto switch at the square groove.

XHZL-□□
Auto Switch Mounting Groove Dimensions

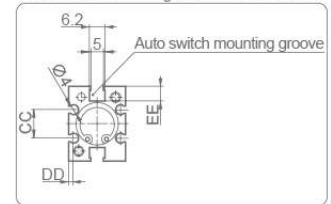

Note) Through-hole mounting is not possible when using the auto switch at the square groove.

Dimension Sheet

Bore(mm)	A	B	C	D	E	F	G	H	I	J	K	K1	K2	K3	ΦL	M	N	O	P	Q	
10	6	25(35)	12	37.8(47.8)	57(67)	35	19.2 ^{+2.2} ₀	11.2 ⁰ _{-0.7}	4 ⁰ _{-0.1}	16	M3×0.5	6	5.5	6	2.6	29(39)	Φ11H9 ^{+0.043} ₀	Dp:2	11.4	M2.5×0.45	3
16	7.5	31(36)	15	45.2(50.2)	70(75)	47	26.9 ^{+2.2} _{0.2}	14.9 ⁰ _{-0.7}	5 ⁰ _{-0.1}	24	M4×0.7	4.5	8	8	3.4	36(41)	Φ17H9 ^{+0.043} ₀	Dp:2	16	M3×0.5	4
20	9.5	36(42)	20	58(64)	90(96)	62	34.3 ^{+2.2} _{0.2}	16.3 ⁰ _{-0.7}	8 ⁰ _{-0.1}	30	M5×0.8	8	10	10	4.3	43(49)	Φ21H9 ^{+0.052} ₀	Dp:3	18.6	M4×0.7	5
25	11	40(50)	25	66.9(76.9)	106(116)	75	41.3 ^{+2.5} _{0.2}	19.3 ⁰ _{-0.8}	10 ⁰ _{-0.1}	36	M6×1	10	12	12	5.1	48(58)	Φ26H9 ^{+0.052} ₀	Dp:3.5	22	M5×0.8	6

Bore(mm)	R	S	T	U	V	W	X	Y	Z	Y1	Y2	AA	BB	CC	DD	EE	
10	5.7	M3×0.5	23	8	21(31)	5 ⁰ _{-0.05}	11	Φ2H9 ^{+0.025} ₀	Dp:3	16.4±0.05	5.2±0.02	7.6±0.02	18	12	-	-	
16	7	M5×0.8	30.6	8	25(30)	8 ⁰ _{-0.05}	13	Φ3H9 ^{+0.025} ₀	Dp:3	23.6±0.05	6.5±0.02	11±0.02	22	15	11.6	2.1	5.8
20	9	M5×0.8	42	10	30(36)	10 ⁰ _{-0.05}	15	Φ4H9 ^{+0.03} ₀	Dp:4	27.6±0.05	7.5±0.02	16.8±0.02	32	18	14	2.1	9
25	12	M5×0.8	52	10	33(43)	12 ⁰ _{-0.05}	20	Φ4H9 ^{+0.03} ₀	Dp:4	33.6±0.05	10±0.02	21.8±0.02	40	22	19	3.5	11.5